

# INSTALLATION SHEET

Keep These Instructions!

PLEASE FOLLOW ALL INSTRUCTIONS AND ALWAYS USE PROTECTIVE EYEWEAR WHEN INSTALLING A DOOR SYSTEM. PLEASE READ INSTRUCTIONS COMPLETELY.

# SERIES 4050 MIRROR SLIDING DOOR

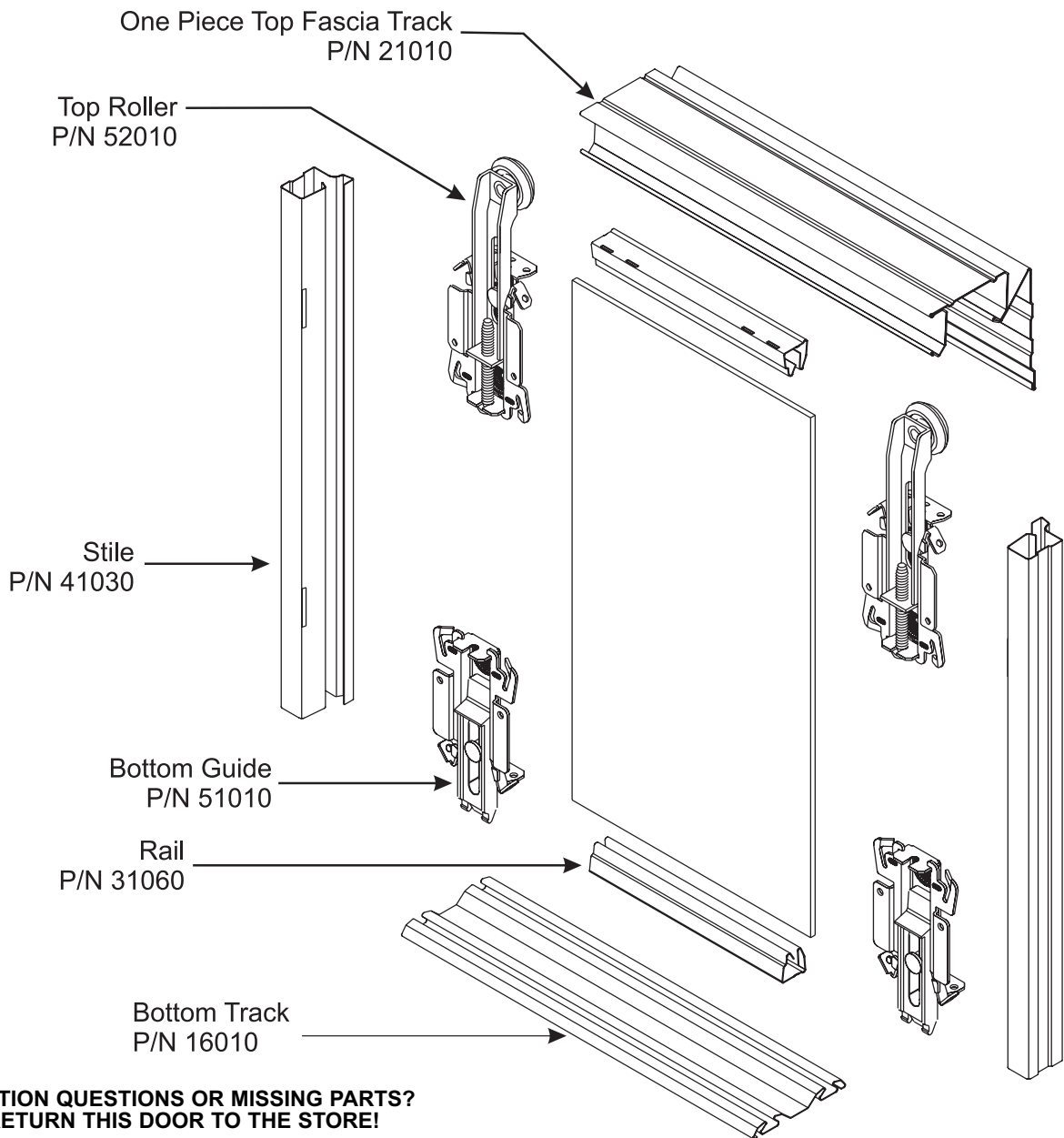

### INSTALLATION QUESTIONS OR MISSING PARTS? DO NOT RETURN THIS DOOR TO THE STORE!

Thank you for purchasing this Slimfold product. We take pride in the products we manufacture and are confident you will be pleased with your selection. However, sometimes a product may leave our factory in less than perfect condition. If you have questions or are missing component parts necessary to complete the installation, **do not return the door to the place of purchase**. Give us a call first. More than likely, we can solve the problem without the hassle and expense of returning the door to the store. **Call Customer Service:** 1-800-633-7553 from 8:00 a.m. to 5:00 p.m. CST, Monday through Friday.



# SLIMFOLD®

*Closet Systems*

P.O. BOX 8577 | DOTHAN, ALABAMA 36304-0577  
**800-633-7553**  
334-793-3462 (fax)  
[www.dunbarton.com](http://www.dunbarton.com)  
email: [slimfold@dunbarton.com](mailto:slimfold@dunbarton.com)

# BEFORE YOU BEGIN

PLEASE FOLLOW ALL INSTRUCTIONS AND ALWAYS USE PROTECTIVE EYEWEAR WHEN INSTALLING A DOOR SYSTEM. PLEASE READ INSTRUCTIONS COMPLETELY.

## Assemble Tools

- Safety glasses
- Phillips head screwdriver
- Straight head screwdriver
- Level
- Tape Measure
- Power drill or screw gun (3/16" bit)

## Measure Opening

Measure the Finished Opening Size; refer to Specifications below to insure proper door size (FIGURE 1). Finished Door width provides for 1-1/2" door overlap at center of opening.

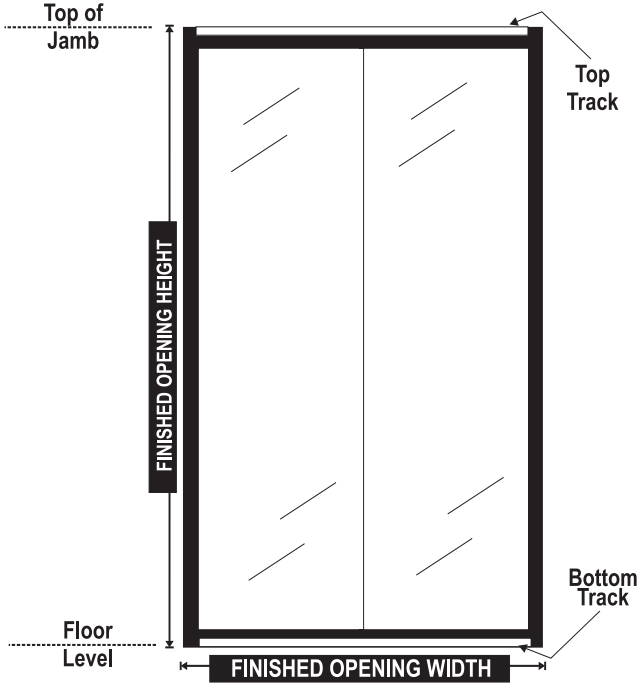

FIGURE 1

3mm mirrors for reach-in closet and passage door applications are CATEGORY II safety-backed to conform with ANSI Z97.1 - 2004 American National Standard for Safety Glazing Materials and CPSC 16 CFR 1201 Consumer Product Safety Commission.

### Specifications STANDARD SIZES—TWO PANEL UNITS FINISHED OPNG. HEIGHTS

Size	Door Width	OPENING WIDTH	6'8" FINISHED OPNG. HEIGHTS Units
4'0" (1219)	24 5/8" (626)	48" (1219)	80 1/2" (2045)
5'0" (1524)	30 5/8" (778)	60" (1524)	
6'0" (1829)	36 5/8" (930)	72" (1829)	

\*Finished Opening Width Tolerance +1"-2" (+25/-50)

\*\*Finished Opening Height Tolerance: +1.5"/+.5" (+38/+13)

All increments shown in parenthesis are metric (millimeter) unless otherwise indicated. Non-standard sizes available; check with your dealer for sizes and availability.

# INSTALLATION

## 1. Remove Door from Packing Material

Carefully open the door package and remove the track packed inside the door (track can be packed separately if requested). Locate hardware bag(s) containing the following components for the 4050 Mirror Sliding Door.

### 4050 MIRROR SLIDING DOOR (2-PANEL):

- Ten Track Screws (P/N 25252709)

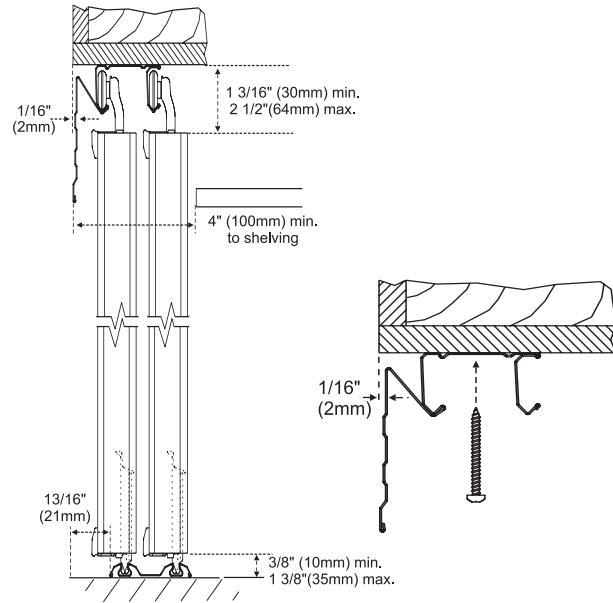

CROSS SECTION DETAIL (Figure 2)

## 2. Set The Tracks

Saw top track, floor track (and fascia) to length if necessary, using a fine-tooth hack saw (Figure 3).

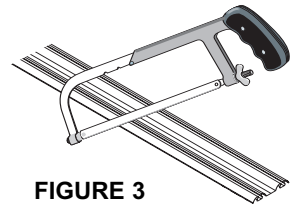

FIGURE 3

**Attach Top Track.** Screw in the fascia track to the header, locating the front edge 1/16" (2mm) from the jamb face (Figure 2).

**Attach Bottom Track.** Locate the leading edge of the floor track 13/16" (5mm) back from the front face of the jamb so doors will hang plumb (Figure 2).

**New Construction:** For best results and performance, it is recommended that the track be put down before laying carpet. Depending upon the height of the finished floor, a continuous wood shim can be placed underneath the track to provide additional clearance between the door and carpet. The carpet can be installed up to the track and the door can be installed later.

**Existing Dwelling:** When installing SLIMFOLD doors in an area where carpet has been previously laid, lay the track on top of the existing carpet and screw into the floor below. **CAUTION: Turn screw slowly to avoid causing a runner in the carpet.**

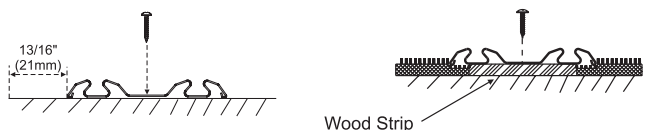

### 3. Install Doors in Opening

Stand behind door on inside of wardrobe. Tip bottom of door outward (about 15") to engage wheels in track. Install the outside or front door first (Figure 3).

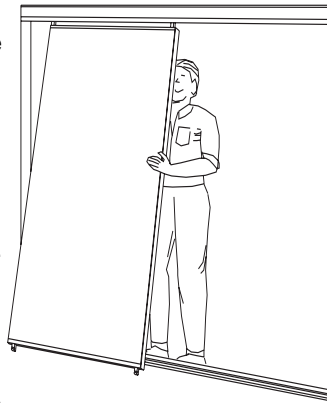

FIGURE 3

### 4. Vertical Adjustment

Use Phillips screwdriver for vertical adjustment at (A), plumbing left door to left jamb, right door to right jamb (Figure 4). (Screw is self-locking in any position.)

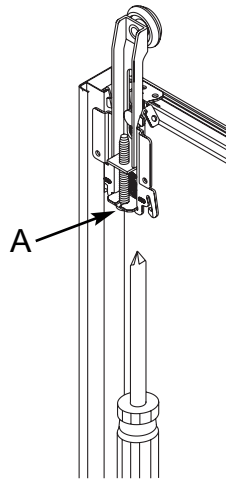

FIGURE 4

### 5. Set Bottom Guide

After obtaining approximately 1/2" clearance at floor, press nylon button guide down with thumb at (B) until hooks (C) snap into floor track. Guide will ride up and down in channel to compensate for uneven floor level, without disengaging door. Guide can be removed by prying up under nylon flange (Figure 5).

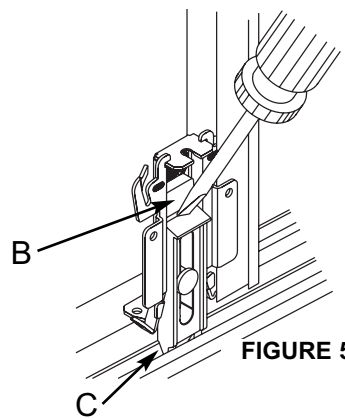

FIGURE 5

### 6. Apply Sealer

Applying a sealer coat to backside of prefinished paneling is recommended. If panels are to be painted, paint both sides with an equal number of coats. Use oil base undercoat if finish will be water-based (latex) paint.

## SLIMFOLD PRODUCTS LIMITED LIFETIME WARRANTY

Slimfold Products Division warrants to the purchaser that its products, when utilized for interior door use, will be free from defects in materials and workmanship for the life of the product.

Slimfold Products manufactured with galvanized steel are additionally warranted against rusting for a period of one (1) year from the date of purchase, provided the finish has not been cut or abraded through the metal. Galvanized steel should be used where air has a high salt content or in locations with high humidity.

This warranty is applicable only when the products covered by it have been installed in accordance with the recommended written installation instructions of Slimfold Products Division and with established building practices, have been accorded treatment which is considered good practice in the building industry regarding storage and maintenance, and have been subjected only to normal use. Because Slimfold Products Division cannot control the manner in which its products are handled after leaving its premises, this warranty does not apply to the finish or other damage occurring during shipment.

**There are no warranties, express or implied, which extend beyond the description on the face hereof, including the implied warranty of merchantability and the implied warranty of fitness for a particular purpose.**

Some states do not allow limitations on how long an implied warranty lasts, so the above limitation may not apply in some cases.

In the event the original consumer purchaser of any Slimfold product believes that the door or any parts thereof covered by this warranty is defective, a letter outlining the alleged defect should be sent postage prepaid to the following address:

**Slimfold Products Division**

**PO Box 8577**

**Dothan, AL 36304-0577**

Any Slimfold Products part covered by this warranty which, upon inspection by an authorized representative of Slimfold Products Division, are found by said representative to be defective, will be repaired or replaced at the option of Slimfold Products Division. The purchase price of the part will be refunded and does not include labor, installation costs, finishing costs, or indirect or consequential damages of any nature. Some states do not allow the exclusion or limitation of incidental or consequential damages, so the above limitation or exclusion may not apply to you.

This warranty bestows certain legal rights, and you may also have other rights which vary from state to state.

## CARING FOR YOUR SLIMFOLD DOOR

### KEEP TRACK FREE OF DIRT AND PAINT!

#### Steel Bifolds

Clean steel surface with a soft cloth using a mild detergent and water. Do not use harsh cleaners or abrasive.

#### Mirrors

- Clean mirror surface with clean, warm water or approved glass cleaner. Do not use any acid or alkali cleaners or cleaners with ammonia base. They will attack front surface, edges and backing of glass.
- Use a clean, soft cloth when cleaning to avoid scratching mirror surface.
- Never spray any cleaner directly on to the mirror. Apply to cloth first, then wipe mirror.
- Be sure to dry all edges thoroughly.



*Closet Systems*

P.O. BOX 8577 | DOTHAN, ALABAMA 36304-0577  
**800-633-7553**  
334-793-3462 (fax)  
[www.dunbarton.com](http://www.dunbarton.com)  
email: [slimfold@dunbarton.com](mailto:slimfold@dunbarton.com)