

INSTALLATION SHEET

Keep These Instructions!

PLEASE FOLLOW ALL INSTRUCTIONS AND ALWAYS USE PROTECTIVE EYEWEAR WHEN INSTALLING A DOOR SYSTEM. PLEASE READ INSTRUCTIONS COMPLETELY.

SERIES 4760 FRAMELESS MIRROR SLIDING DOORS

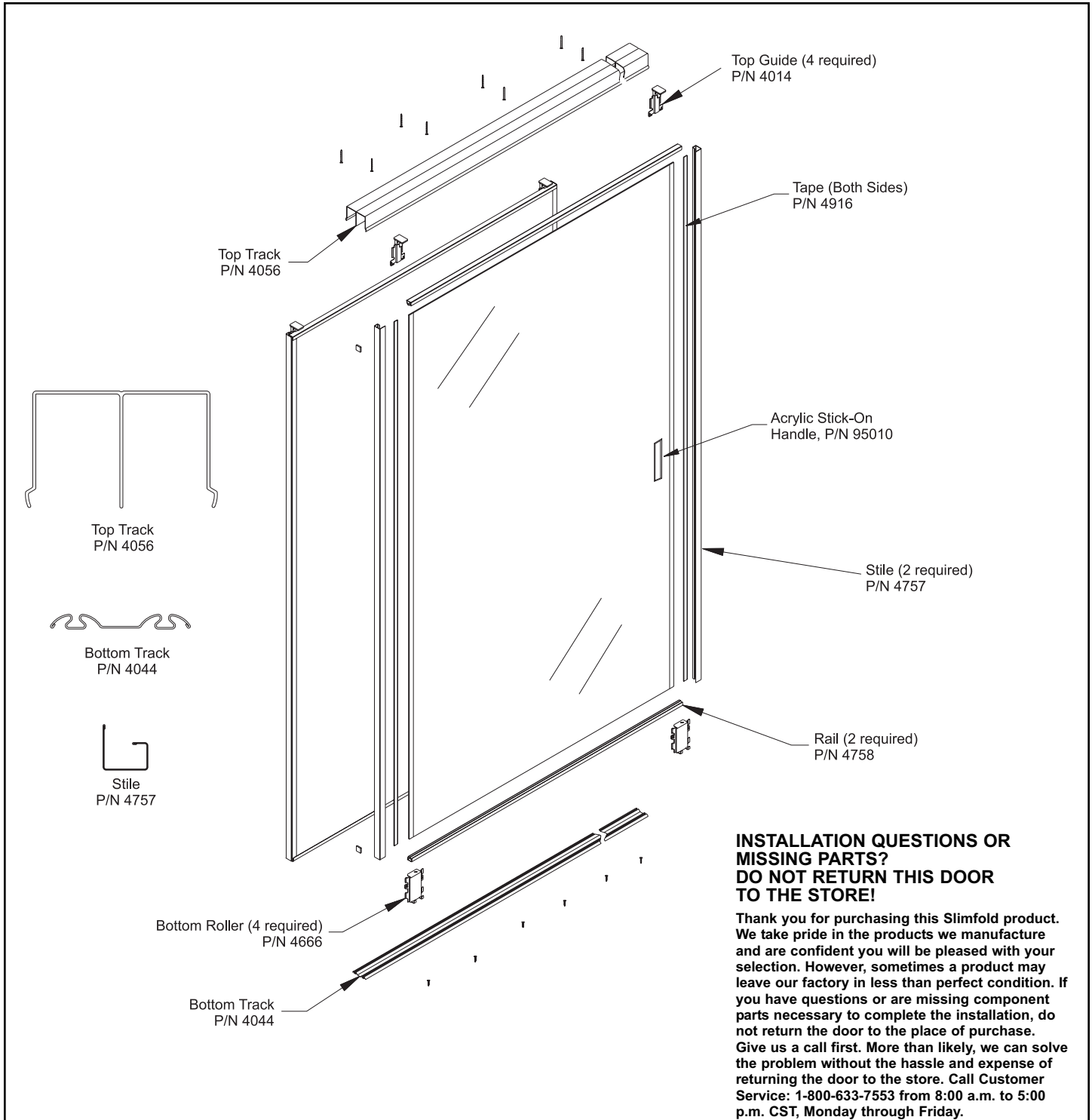

SLIMFOLD™

Closet Systems

Slimfold Products, A Division of the Dunbarton Corporation

P.O. Box 8577, Dothan, AL 36304-0577

Toll Free: (800) 633-7553 Tel: (334) 794-0661 Fax: (334) 793-7022

Web Page: www.dunbarton.com E-mail: slimfold@dunbarton.com

BEFORE YOU BEGIN

PLEASE FOLLOW ALL INSTRUCTIONS AND ALWAYS USE PROTECTIVE EYEWEAR WHEN INSTALLING A DOOR SYSTEM. PLEASE READ INSTRUCTIONS COMPLETELY.

Assemble Tools

- Safety glasses
- Phillips head screwdriver
- Straight head screwdriver
- Level
- Tape Measure
- Power drill or screw gun (3/16" bit)

Measure Opening

Measure the Finished Opening Size; refer to Specifications below to insure proper door size (FIGURE 1).

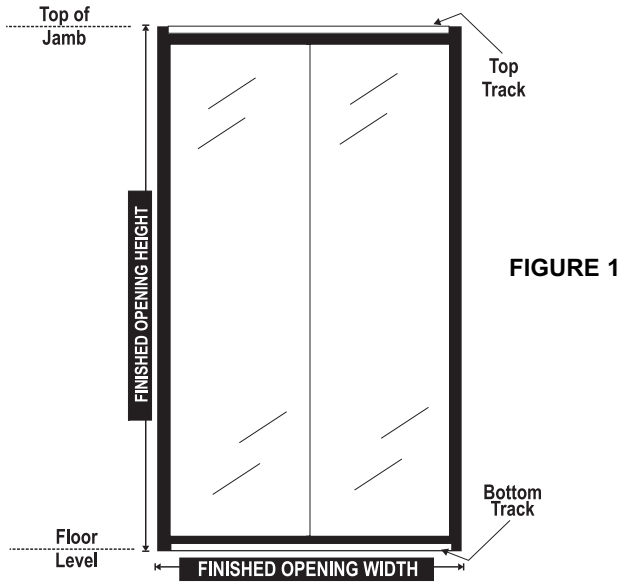

FIGURE 1

For sliding mirror doors up to 48" x 96", using 1/8", 5/32" or 3/16" safety glazed mirrors that conform to ANSI Z97.1 or CPSC42FR 1428; 16CFR Part 1201.

All mirrors should have bevel or pencil edges on long sides, and cut edges on short sides.

Specifications

STANDARD SIZES—TWO PANEL UNITS

FINISHED OPENING WIDTH FINISHED OPNG. HEIGHTS

| Size | Door Width | OPENING WIDTH | 6'8" Units | 8" Units |
|----------------|--|---------------|--|---------------|
| 4'0" (1219) | 24 ⁵ / ₈ " (626) | 48" (1219) | 80 ¹ / ₂ " (2045) | 96" (2438) |
| 5'0" (1524) | 30 ⁵ / ₈ " (778) | 60" (1524) | | |
| 6'0" (1829) | 36 ⁵ / ₈ " (930) | 72" (1829) | | |
| 8'0" (2438) | 48 ⁵ / ₈ " (1235) | 96" (2438) | | |

STANDARD SIZES—THREE PANEL UNITS

FINISHED OPENING WIDTH FINISHED OPNG. HEIGHTS

| Size | Door Width | OPENING WIDTH | 6'8" Units | 8" Units |
|-----------------|--|----------------|--|---------------|
| 9'0" (2743) | 36 ⁵ / ₈ " (930) | 108" (2743) | 80 ¹ / ₂ " (2045) | 96" (2438) |
| 12'0" (3658) | 48 ⁵ / ₈ " (1235) | 144" (3658) | | |

Finished Opening Width Tolerance +1/4"/-0 (+6/-0)

All increments shown in (parenthesis) are metric (millimeter) unless otherwise indicated. Non-standard sizes available; check with your dealer for sizes and availability.

INSTALLATION

1. Remove Door from Packing Material

Carefully open the door package and remove the track packed inside the door (track can be packed separately if requested). Locate hardware bag(s) containing the following components for two-panel doors:

MODEL 4760 SLIDER INCLUDES:

- Ten Track Screws (P/N 25252709)
(Hardware Bag P/N 8L201001)

CROSS SECTION DETAIL

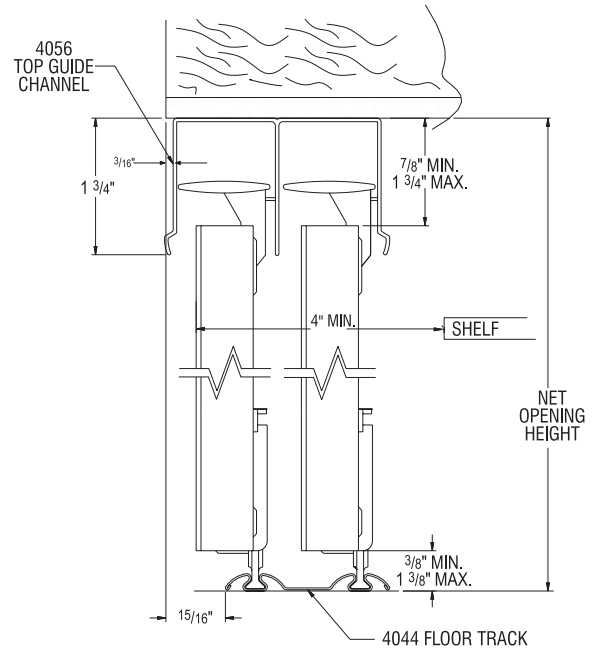

2. Cut Tracks To Size

Saw 4056 top guide track to length if necessary, using a fine-tooth (32 teeth/inch) hacksaw. Before cutting, insert 2 x 4 wood blocks between channels next to saw cut, and hold firmly together for smoother cutting. It is not necessary to support the 4044 floor track while cutting (Figure 2).

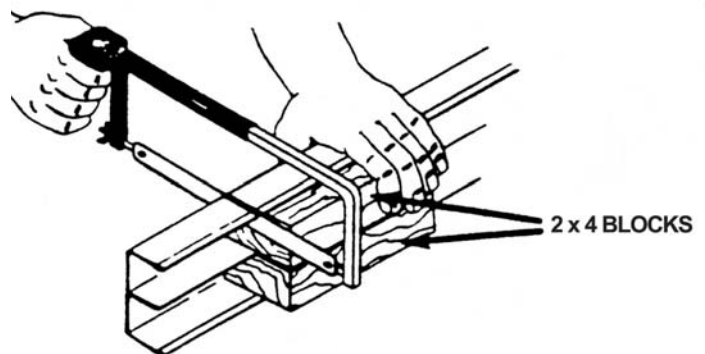
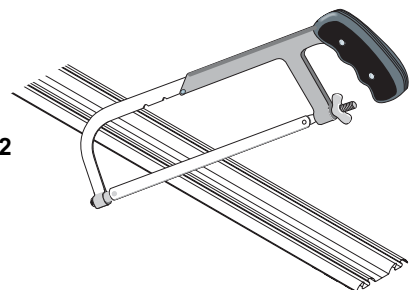

FIGURE 2



3. Set The Track

Screw 4056 steel guide track to header, locating front edge 3/16" back from face of jamb. Locate leading edge of 4044 floor track 15/16" from front face of jamb, so doors will hang plumb.

New Construction: For best results and performance, it is recommended that the track be put down before laying carpet. Depending upon the height of the finished floor, a continuous wood shim can be placed underneath the track to provide additional clearance between the door and carpet. The carpet can be installed up to the track and the door can be installed later.

Existing Dwelling: When installing SLIMFOLD doors in an area where carpet has been previously laid, lay the track on top of the existing carpet and screw into the floor below. **CAUTION: Turn screw slowly to avoid causing a runner in the carpet.**

4. Install Doors In Opening

Doors are shipped with the bottom rollers fully retracted. Before proceeding to install doors, extend rollers 1/2" by turning the adjusting bolt counterclockwise.

Install rear door first. Insert top of door into the top guide channel first, then swing bottom of door over bottom track and lower rollers into rear groove. Install front door in the same manner (Figure 4).

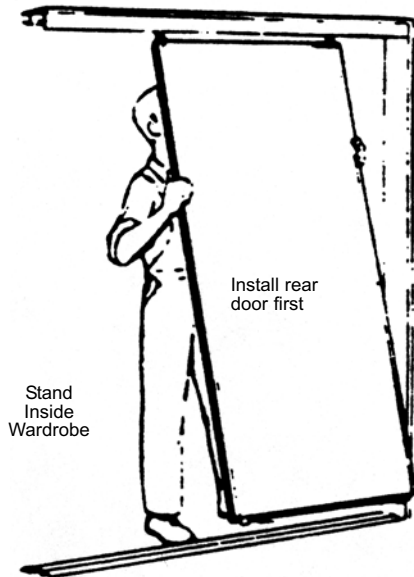

FIGURE 4

5. Adjust Doors

To perfectly align the doors with the side walls or end panels, use a screwdriver and turn the adjustment screw in the bottom wheel to the left or right to raise or lower the door (Figure 5).

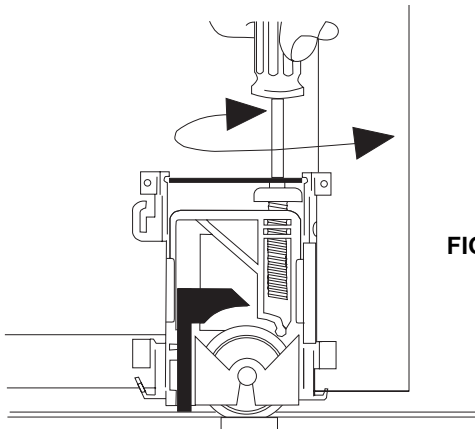

FIGURE 5

6. Engage Jump-Resistant Device in the Bottom Wheel
Open clip and push down into the floor track channel. Close the clip (Figure 6).

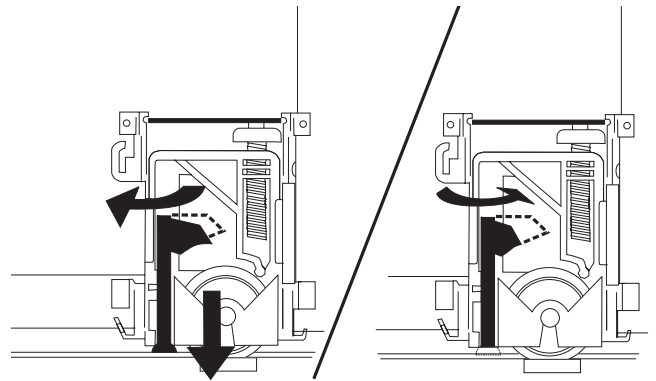

FIGURE 6

7. Attach Edge Pulls

Attach 4720 pulls to the stiles adjacent to the wall jambs. Using the pull as a template, pierce or drill 3/16" holes in the stile at a convenient height (approx. 36"), and attach to pull with #8/6 flat head screws that thread into the nut as shown. Be sure screws are tight. Affix 4026 self-adhesive bumpers over screw heads (Figure 7).

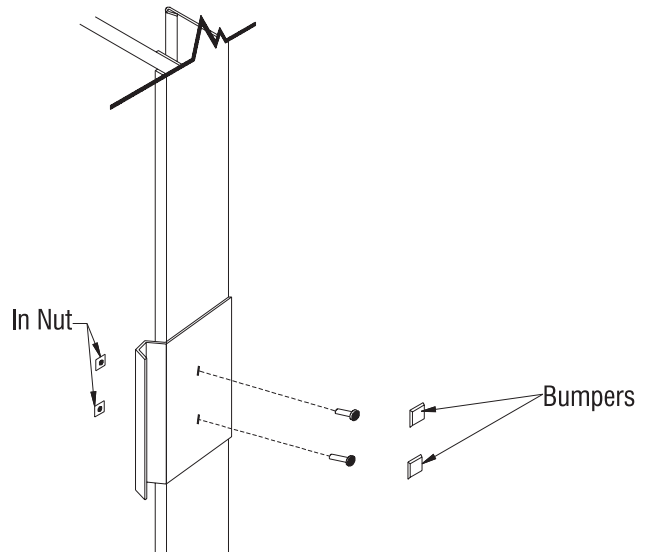

FIGURE 7

**SLIMFOLD PRODUCTS LIMITED
LIFETIME WARRANTY**

Slimfold Products Division warrants to the purchaser that its products, when utilized for interior door use, will be free from defects in materials and workmanship for the life of the product.

Slimfold Products manufactured with galvanized steel are additionally warranted against rusting for a period of one (1) year from the date of purchase, provided the finish has not been cut or abraded through the metal. Galvanized steel should be used where air has a high salt content or in locations with high humidity.

This warranty is applicable only when the products covered by it have been installed in accordance with the recommended written installation instructions of Slimfold Products Division and with established building practices, have been accorded treatment which is considered good practice in the building industry regarding storage and maintenance, and have been subjected only to normal use. Because Slimfold Products Division cannot control the manner in which its products are handled after leaving its premises, this warranty does not apply to the finish or other damage occurring during shipment.

There are no warranties, express or implied, which extend beyond the description on the face hereof, including

the implied warranty of merchantability and the implied warranty of fitness for a particular purpose.

Some states do not allow limitations on how long an implied warranty lasts, so the above limitation may not apply in some cases.

In the event the original consumer purchaser of any Slimfold product believes that the door or any parts thereof covered by this warranty is defective, a letter outlining the alleged defect should be sent postage prepaid to the following address:

**Slimfold Products Division
PO Box 8577
Dothan, AL 36304-0577**

Any Slimfold Products part covered by this warranty which, upon inspection by an authorized representative of Slimfold Products Division, are found by said representative to be defective, will be repaired or replaced at the option of Slimfold Products Division. The purchase price of the part will be refunded and does not include labor, installation costs, finishing costs, or indirect or consequential damages of any nature. Some states do not allow the exclusion or limitation of incidental or consequential damages, so the above limitation or exclusion may not apply to you.

This warranty bestows certain legal rights, and you may also have other rights which vary from state to state.

**CARING FOR YOUR SLIMFOLD DOOR
KEEP TRACK FREE OF DIRT AND PAINT!**

Steel Bifolds

Clean steel surface with a soft cloth using a mild detergent and water. Do not use harsh cleaners or abrasive.

Mirrors

- Clean mirror surface with clean, warm water or approved glass cleaner. Do not use any acid or alkali cleaners or cleaners with ammonia base. They will attack front surface, edges and backing of glass.
- Use a clean, soft cloth when cleaning to avoid scratching mirror surface.
- Never spray any cleaner directly on to the mirror. Apply to cloth first, then wipe mirror.
- Be sure to dry all edges thoroughly.



SLIMFOLD™

Closet Systems

Slimfold Products, A Division of the Dunbarton Corporation

P.O. Box 8577, Dothan, AL 36304-0577

Toll Free: (800) 633-7553 Tel: (334) 794-0661 Fax: (334) 793-7022

Web Page: www.dunbarton.com E-mail: slimfold@dunbarton.com

P/N 82800255 SF410 Rev. 4/09